

DGD、EGS系列手轮机构
DGD & EGS Series Gear Box



无锡福斯拓科科技有限公司
WUXI FORCE & TORQUE TECHNOLOGY CO., LTD.

◆工厂介绍 Company Introduction



无锡福斯拓科科技有限公司是一家深受国内外客户及用户认可的气动阀门执行器专业生产厂家。凭借20年的行业经验，福斯拓科致力于为客户提供世界一流的产品和服务。

福斯拓科产品主要包括气动阀门执行器、气动阀门附件（手轮机构、限位开关，电磁阀，过滤减压阀，电气定位器等控制附件）及气动球阀、气动蝶阀等成套阀门产品。

气动执行器产品主要包括不锈钢系列气动执行器；RT系列齿轮齿条气动执行器；HPY系列拨叉式气动执行器、拨叉式液动执行器；HPL系列直行程气动执行器、直行程液动执行器。执行器缸径从 $\phi 32 \sim \phi 1000\text{mm}$ 近百个规格，扭矩范围覆盖 $5\text{Nm} \sim 300000\text{Nm}$ 。

福斯拓科秉承“专注、专业、卓越”的经营理念，将竭诚为新老客户提供更好的技术，完善的产品和优质的服务。

Wuxi Force & Torque Technology Co., Ltd. is a well recognized world leader and reliable manufacturer for pneumatic actuator and pneumatic valve in China. With over 20 years innovation and extensive industry experience, Force & Torque provides first class products and services for customers worldwide.

Force & Torque supplies pneumatic actuators and valve control accessories such as manual override, limit switch box, solenoid valve, filter regulator, valve position feedback device etc.. Additionally, Force & Torque provides professional valve automation solutions like pneumatic ball valve, pneumatic butterfly valve etc. for diverse applications.

The wide variety of actuators include stainless steel pneumatic actuator, RT series rack and pinion actuator, HPY series scotch yoke pneumatic actuator and scotch yoke hydraulic actuator, HPL series linear pneumatic actuator and linear hydraulic actuator. Actuator ranges from $\phi 32$ to $\phi 1000$, torque covers from 5Nm to 300000Nm .

Focusing on the mindset ‘Absorbed, Professional, Excellent’, Wuxi Force & Torque devotes to serve customers with more excellent technology, innovative products and best service.

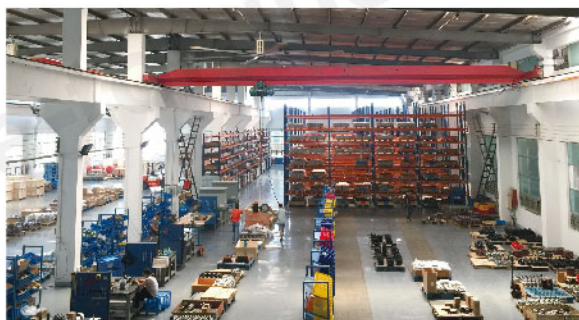

◆ 手轮机构主要特点

Main Features

- 结构紧凑，个性化多项设计可选
- 易操作
- 结构合理，故障率低
- 材质可选，适合各种环境
- 开位、关位 $\pm 5^\circ$ 可调
- 防护等级可达到IP67
- 工作温度：
 - 标准型：-20℃-- +80℃
 - 低温型：-40℃-- +80℃
 - 高温型：-15℃-- +120℃
- 上下安装法兰符合ISO5211标准
- DGD手轮机构手自动离合切换，适合单、双作用执行器
- EGS手轮机构无须切换，专门为单作用设计，更加安全可靠
- DGD系列可选自动泄压阀/平衡阀
- 规格多，输出扭矩范围广
- 表面处理可选，喷漆或环氧树脂喷涂
- Compact structure, individual and diversified design
- Easy operation
- Reasonable structure, low failure rate
- Materials alternative, applicable for various environments
- $\pm 5^\circ$ adjustment at both open and close directions easily and precisely.
- Enclosure: Sealed to IP67
- Operating temperature:
 - Standard: -20℃~+80℃
 - Low temperature: -40℃~+80℃
 - High temperature: -15℃~+120℃
- The upper and lower mounting flanges conform to ISO5211
- DGD gear box hand automatic clutch switch, applicable for both spring and double acting actuators
- EGS gear box without switching, special design for single acting actuators, more safety and reliable
- DGD series of optional automatic pressure relief valve or equalising valve
- Broad Specifications, Wide range of output torque
- Surface Treatment Optional: painted or powder polyester painted



◆ DGD系列手轮机构
DGD Series Gear Box

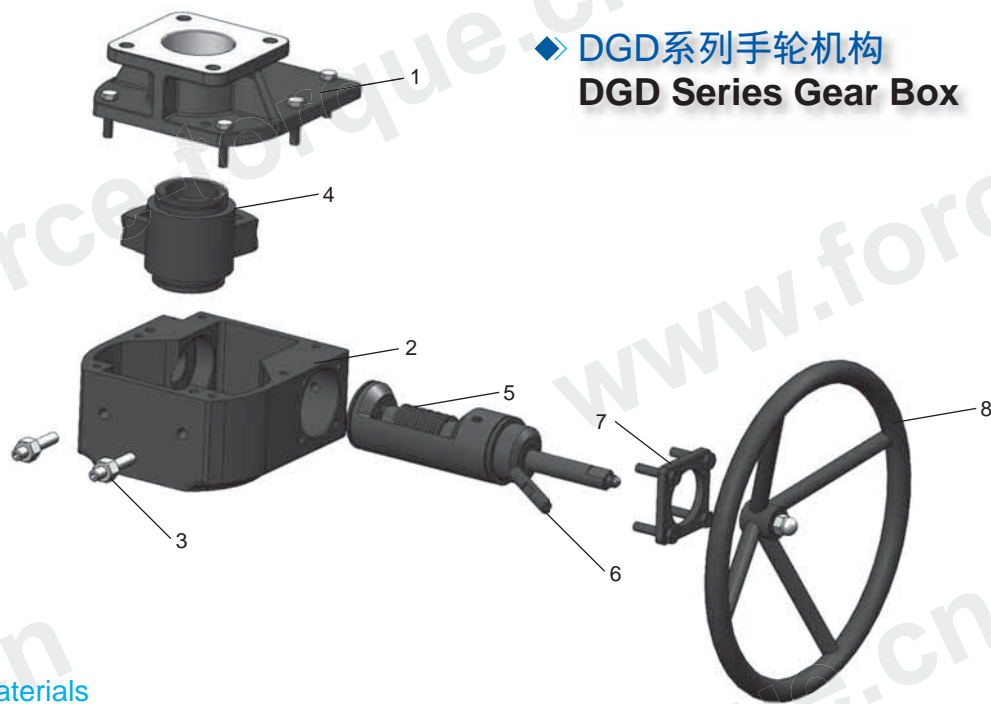

材料表 Materials

序号 No.	零件名称 Name	材料 Materials	备注 Remarks
1	上壳体 Cap	铝合金 Aluminium Alloy	DGD025~100铝合金 DGD025~100Aluminium Alloy
		球墨铸铁 Ductile Iron	DGD200~DGD800球墨铸铁 DGD200~DGD800Ductile Iron
2	下壳体 Body	铝合金 Aluminium Alloy	DGD025~100铝合金 DGD025~100Aluminium Alloy
		球墨铸铁 Ductile Iron	DGD200~DGD800球墨铸铁 DGD200~DGD800Ductile Iron
3	调整螺栓 Adjust screws	碳钢 Carbon Steel	
4	蜗轮 Worm gear	球墨铸铁 Ductile Iron	
5	蜗杆组件 Worm	碳钢、球墨铸铁 Carbon Steel/Ductile Iron	
6	切换手柄 Switch handle	碳钢 Carbon Steel	
7	压盖 Gland	碳钢 Carbon Steel	
8	手轮盘 Hand wheel	碳钢 Carbon Steel	可选材质:铸铁 Optional material: Iron

外型尺寸 Dimensions (without shaft)

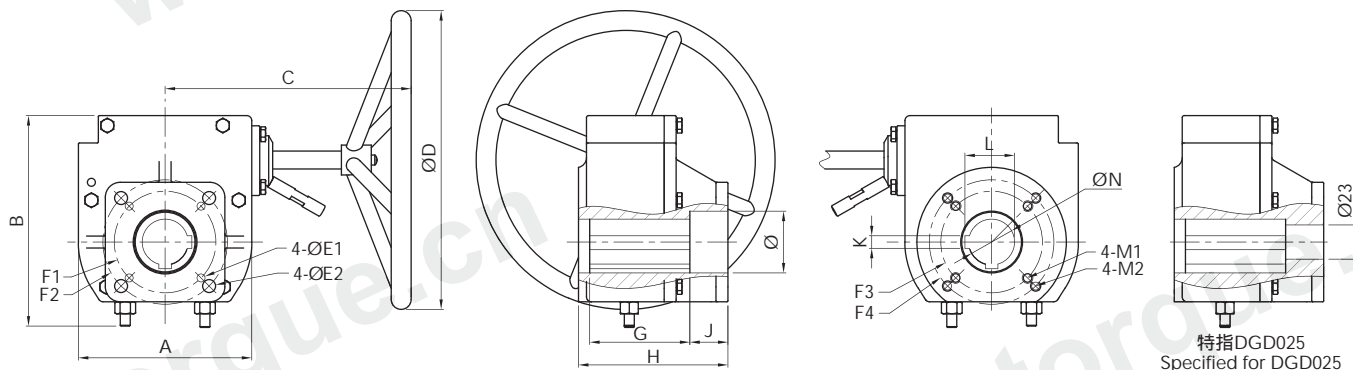

型号 Model	A	B	C	ØD	ØE1	ØE2	F1	F2	G	H	J	K	L	M1	M2	F3	F4	ØN
DGD025	102	145	167	145	7	9	50	70	63	120	44	6	30.8	M6	M8	50	70	28
DGD050	125	166	230	350	—	11	—	102	82	143	45	10	41.3	M8	M10	70	102	38
DGD100	174	207	284	400	—	13	—	125	83	150	52	14	49.8	M10	M12	102	125	46
DGD200	234	267	359	500	18	22	140	165	101	173	48	18	64.4	M16	—	140	—	60
DGD201	234	267	359	500	18	22	140	165	101	173	48	18	64.4	—	M20	—	165	60
DGD400	292	325	425	600	—	22	—	165	125	186	38	22	77.4	—	M20	—	165	72
DGD800	438	385	463	500	8-Ø18	—	254	—	164	248	57	20	79.9	8-M16	—	254	—	75

含轴尺寸表 Dimensions (with shaft)

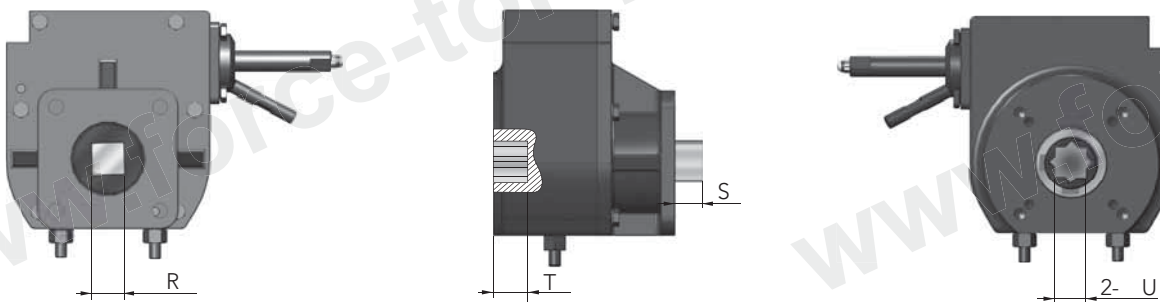

Model	R	S	T	U
DGD025	17	20	19	17
DGD050	22	25	24	22
DGD100	27	30	29	27
DGD200	36	39	38	36

Model	R	S	T	U
DGD201	46	49	38	36
DGD400	46	50	48	46
DGD800	55	60	57	55

◆ EGS系列手轮机构
EGS Series Gear Box



材料表 Materials

序号 No.	零件名称 Name	材料 Materials	备注 Remarks
1	上壳体 Cap	铝合金 Aluminium Alloy	EGS050~100铝合金 EGS050~100Aluminium Alloy
		球墨铸铁 Ductile Iron	EGS200~800球墨铸铁 EGS200~800Ductile Iron
2	下壳体 Body	铝合金 Aluminium Alloy	EGS050~100铝合金 EGS050~100Aluminium Alloy
		球墨铸铁 Ductile Iron	EGS200~800球墨铸铁 EGS200~800Ductile Iron
3	调整螺栓 Adjust screw	碳钢 Carbon Steel	
4	蜗轮 Worm gear	球墨铸铁 Ductile Iron	
5	蜗杆组件 Worm	碳钢、球墨铸铁 Carbon Steel/Ductile Iron	
6	手轮盘 Hand wheel	碳钢 Carbon Steel	可选材质: 铸铁 Optional material: Iron

外型尺寸 Dimensions (without shaft)

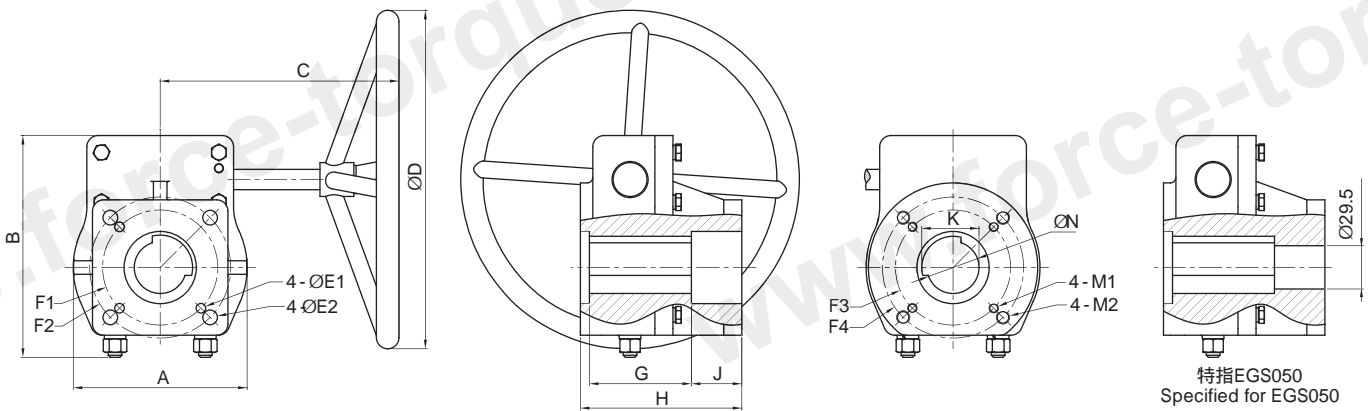

型号 Model	A	B	C	ØD	ØE1	ØE2	F1	F2	G	H	J	K	M1	M2	F3	F4	ØN	key
EGS050	106	155	230	350	9	11	70	102	58	120	48	41.3	M8	M10	70	102	38	10
EGS100	154	195	284	400	—	13	—	125	82	135	53	49.8	M10	M12	102	125	46	14
EGS200	234	260	359	500	18	22	140	165	100	152	36	64.4	M16	—	140	—	60	18
EGS201	234	260	359	500	18	22	140	165	100	152	36	64.4	—	M20	—	165	60	18
EGS400	293	304	292	900	—	22	—	165	118	175	28	77.4	—	M20	—	165	72	22
EGS800	438	385	463	500	8-Ø18	—	254	—	164	248	57	79.9	8-M16	—	254	—	75	20

含轴尺寸表 Dimensions (with shaft)

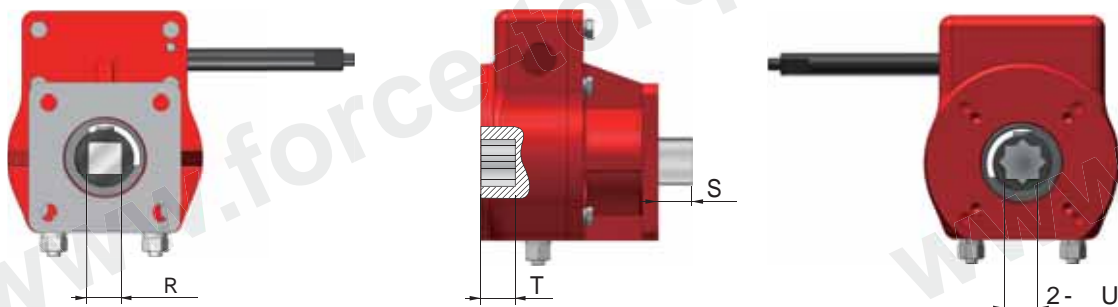

Model	R	S	T	U
EGS050	22	25	24	22
EGS100	27	30	29	27
EGS200	36	39	38	36

Model	R	S	T	U
EGS201	46	49	38	36
EGS400	46	50	48	46
EGS800	55	60	57	55

◆ 可选配组件

Optional Components

- 手轮盘 Hand Wheel



球墨铸铁件 Iron Casting



冲压件 Stamping

• 传动轴 Shaft

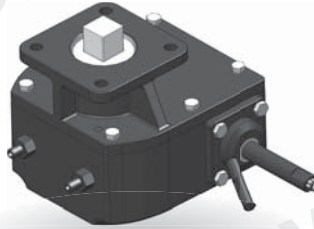
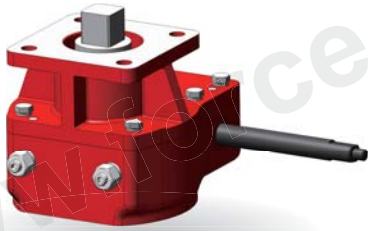

• 泄压阀 Vent valve

• 平衡阀 Equalising valve

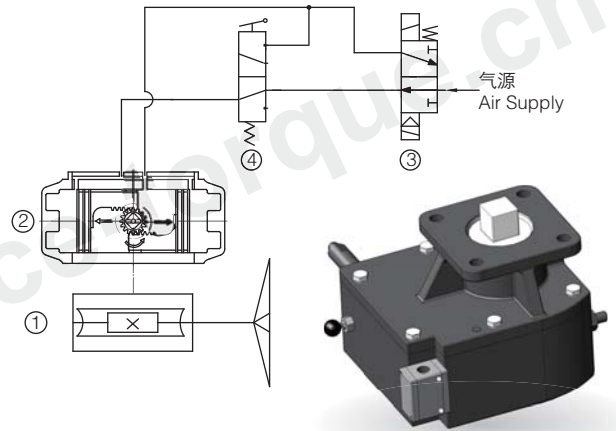
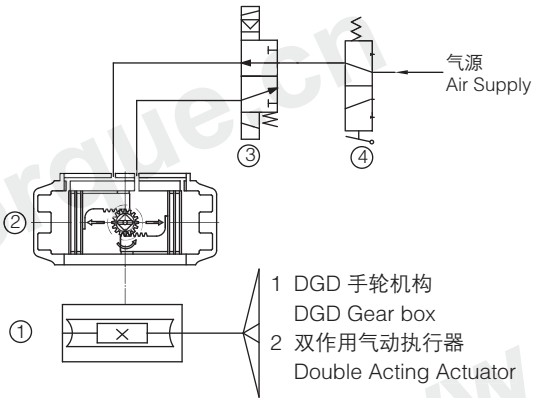

◆ **MG系列**
Manual Gear

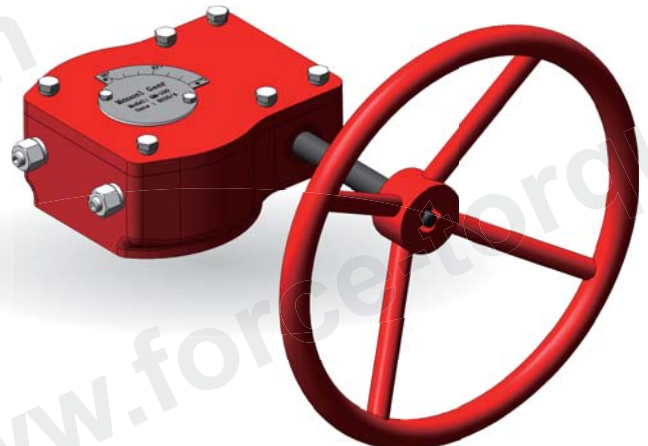

◆ 订购信息 How to order

UNIT 单元	1	2	3	4	5	6	7	Product code 产品代号
CONTENT 内容	DGD	050	1	1	1	0	2	DGD050-11102
EXPLAIN 说明	Series 系列	输出扭矩 Output Torque	泄压阀 Vent Valve	传动轴 Shaft	铸造型手轮盘 Cast iron hand wheel	表面黑色 Black	低温型 Low TEMP	

DGD	离合式手轮机构 Decutchable gear box for DA/SR	025	250Nm	0	不含中轴 without shaft	0	冲压手轮盘 Stamping hand wheel	0	常温型 Standard TEMP
		050	500Nm						
		100	1000Nm						
EGS	单作用手轮机构 Emergency gear box for SR	200	2000Nm	1	含中轴 with shaft	1	铸造型手轮盘 Cast iron hand wheel	1	高温型 High TEMP
		201	2000Nm						
MG	手动齿轮箱 Manual Gear	400	4000Nm	2					低温型 Low TEMP
		800	8000Nm						

0	不含泄压阀等 No Vent Valve etc.
1	泄压阀 Vent Valve
2	平衡阀 Equalising Valve

0	黑色 Black
1	红色 Red
2	客户颜色 Custom color



FT® **FORCE & TORQUE**

无锡福斯拓科科技有限公司
WUXI FORCE & TORQUE TECHNOLOGY CO., LTD.

地址: 无锡市新吴区新华路26号

Add: No.26 Xinhua Road, Xinwu District, Wuxi, Jiangsu, China

电话 (Tel): +86-510-88550590/91/92

传真 (Fax): +86-510-88550590/91/92-812

E-mail: sales@force-torque.cn Http://www.force-torque.cn

我公司保留对产品样本中所有数据更改的权利。

Due to continuous development of our product range,
we reserve the right to modify the dimensions and information contained in this catalogue.